

# CBCS SCHEME

USN

--	--	--	--	--	--	--	--	--	--

17ME54

Fifth Semester B.E. Degree Examination, Jan./Feb. 2023

## Design of Machine Elements – I

Time: 3 hrs.

Max. Marks: 100

- Note: 1. Answer any FIVE full questions, choosing ONE full question from each module.  
2. Use of design data hand book is permitted.  
3. Missing data, if any, may be suitably assumed.

### Module-1

- 1 a. Explain : i) Standards and codes ii) Meaning of FG200 SG400/15 (06 Marks)  
b. Briefly explain the process of mechanical engineering design. (04 Marks)  
c. Determine the max tensile and maximum shear stress for the Fig.Q1(c) shown below :

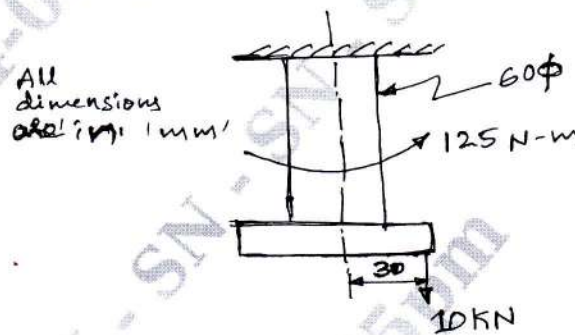

Fig.Q1(c)

(10 Marks)

OR

- 2 a. Define stress concentration and explain any two methods to reduce stress concentrations with sketches. (06 Marks)  
b. Determine the maximum stresses in the following cases :  
i) A rectangular plate of 50mm × 80mm with a hole of 10mm diameter in the center is loaded in axial tension of 10kN. Thickness of plate is 10mm.  
ii) A circular shaft of 45mm diameter stepped down to 30mm diameter having a fillet radius 6mm subjected to a twisting moment of 150N-m. (14 Marks)

### Module-2

- 3 a. A cantilever beam of width 50mm depth 150mm is 1.5m long. It is struck by a weight of 1000N that from a height of 10mm at its free end. Determine the following :  
i) Impact factor  
ii) Instantaneous maximum deflection  
iii) Instantaneous maximum stress  
iv) Instantaneous maximum load. Take  $E = 20.6 \times 10^4 \text{ N/mm}^2$ . (10 Marks)  
b. A 5kg block is dropped from a height of 200mm on to a beam as shown in Fig.Q3(b). The material has an allowable stress of 50MPa. Determine the dimensions of the rectangular cross section whose depth is 1.5 times the width. Take  $E = 70 \text{ GPa}$ .

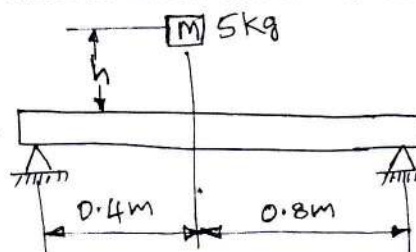

Fig.Q3(b)

(10 Marks)

Important Note : 1. On completing your answers, compulsorily draw diagonal cross lines on the remaining blank pages.  
2. Any revealing of identification, appeal to evaluator and/or equations written eg. 42+8 = 50, will be treated as malpractice.

OR

- 4 a. Explain about cumulative fatigue damage. (05 Marks)
- b. Determine the maximum load for simply supported beam cyclically load as shown in Fig.Q4(b). The ultimate strength is 700MPa, the yield point in tension is 520MPa and the endurance limit in reversed bending is 320MPa. Use a factor of safety of 1.25. The load, size and surface correction factors are 1, 0.75 and 0.9 respectively.

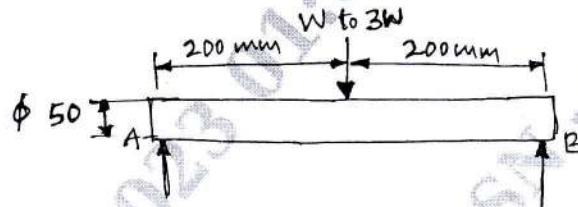

Fig.Q4(b)

(15 Marks)

**Module-3**

- 5 A shaft is supported by two bearings placed 1100mm apart. A pulley of diameter 620mm is keyed at 400mm to the right from the left hand bearing and this drives a pulley directly it with a maximum tension of 2.75kN. Another pulley of diameter 400mm is placed 200mm to the left of right hand bearing and is driven with a motor placed horizontally to the right. The angle of contact of the pulley is  $180^\circ$  and  $\mu = 0.3$ . Find the diameter of the shaft. Assume  $C_m = 3$ ,  $C_t = 2.5$ ,  $\sigma_y = 190$  MPa and  $\sigma_{ut} = 300$ MPa. (20 Marks)

OR

- 6 a. A rectangular sunk key 14mm wide, 10mm thick and 75mm long is required to transmit 1200N-m torque from a 50mm diameter solid shaft. Determine whether the length is sufficient or not if the permissible shear stress and compressive stresses are limited to 56MPa and 168MPa. (06 Marks)
- b. Design an old ham's coupling to transmit 5KW of power at 1000rpm. Maximum allowable pressure between the faces of the slots and the torque is  $8\text{N/mm}^2$ . The allowable value of shear stress and compressive stress for the shaft and key material may be taken as  $40\text{N/mm}^2$  and  $80\text{N/mm}^2$  respectively. (14 Marks)

**Module-4**

- 7 a. Two plates of 10mm thick each are to be joined by means of a single riveted double strap butt joint. Determine the diameter of the rivet, pitch, strap thickness and efficiency of the joint. Take  $\sigma_t = 80$ MPa and  $\tau = 60$ Mpa. (10 Marks)
- b. A riveted joint is consisting of four identical rivets is subjected to an eccentric force of 5kN as shown in Fig.Q7(b). Determine the diameter of rivets, if the permissible shear stress is 60MPa.

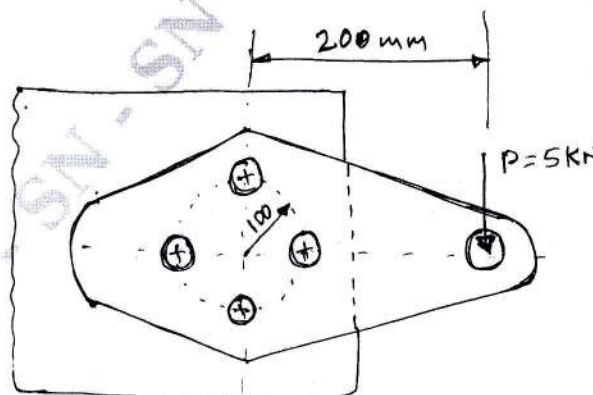

Fig.Q7(b)

(10 Marks)



OR

- 8 a. A 80mm wide 12mm thick plate carrying an axial load of 96kN is welded to a support as shown in Fig.Q8(a). The allowable tensile and shear stress in the weld are 100MPa and 70MPa respectively. Find the length of each parallel fillet weld, for static : loading ad dynamic loading cases.

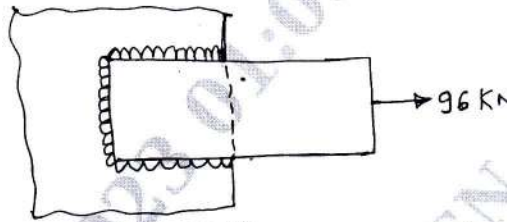

Fig.Q8(a)

(10 Marks)

- b. A 16mm thick plate is welded to a vertical support by two fillet welds as shown in Fig.Q8(b). Determine the size of weld, if the permissible shear stress for the weld material is 75MPa.

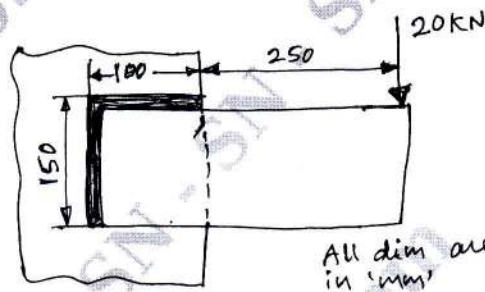

Fig.Q8(b)

(10 Marks)

Module-5

- 9 a. A flat circular plate is used to close the flanged end of a pressure vessel of internal diameter 300mm. The vessel carries a fluid at a pressure of  $0.7\text{N/mm}^2$ . A copper asbestos gasket is used to make the joint leak proof. Twelve bolts are used to fasten the cover plate on to the pressure vessel. Find the size of the bolts so that the stress in the bolt is not to exceed  $100\text{N/mm}^2$ . (10 Marks)
- b. A bracket is bolted as shown in Fig.Q9(b). All the bolts are identical and have yield strength of 400MPa. Determine the size of bolts. Use FOS = 3.

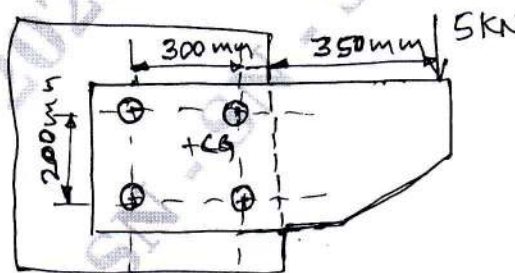

Fig.Q9(b)

(10 Marks)

OR

- 10 a. Explain self locking in power screw and derive an equation for torque required to raise the load on a square thread. (10 Marks)
- b. The square thread of a screw jack with a specification of  $80 \times 16$ , with a double start is to raise a load of 100kN. The mean collar diameter is 130mm the co-efficient of friction for the threads and collar are 0.1 and 0.12 respectively. Determine :
- Torque required to raise the load
  - Efficiency of the screw.

(10 Marks)